

FILE NO.	JPM385A
PART NO.	-

REVISIONS				
REV.	DESCRIPTION	DATE	ECO No.	APP'VD
A	RELEASE TO PRODUCT	2010/11/03		CHNAG

NOTE :

- 1.MATERIAL : SPCC t=1.5m/m=0.059in=16ga ◦
- 2.FINISH : POWDER COATING ◦
- 3.COLOR : BLACK ◦
- 4.SIZE :
427x273.5x44(1U) m/m(WxDxH) ◦
16.8x10.8x1.73 in(WxDxH) ◦
- 5.WEIGHT:
4.7 kg
10.3 lb.
- 6.ADAPTER SPEC:
LC ADAPTER SC FOOTPRINT S.M. PhBr x 24pcs
INSERTION LOSS: 0.20dB/0.30dB (TYP./MAX.)
RETENTION FORCE IS 100GF(0.98N)~300GF(2.94N).
- 7.BLACK BOX P/N:JPM385A ◦

The Degrees is 80°

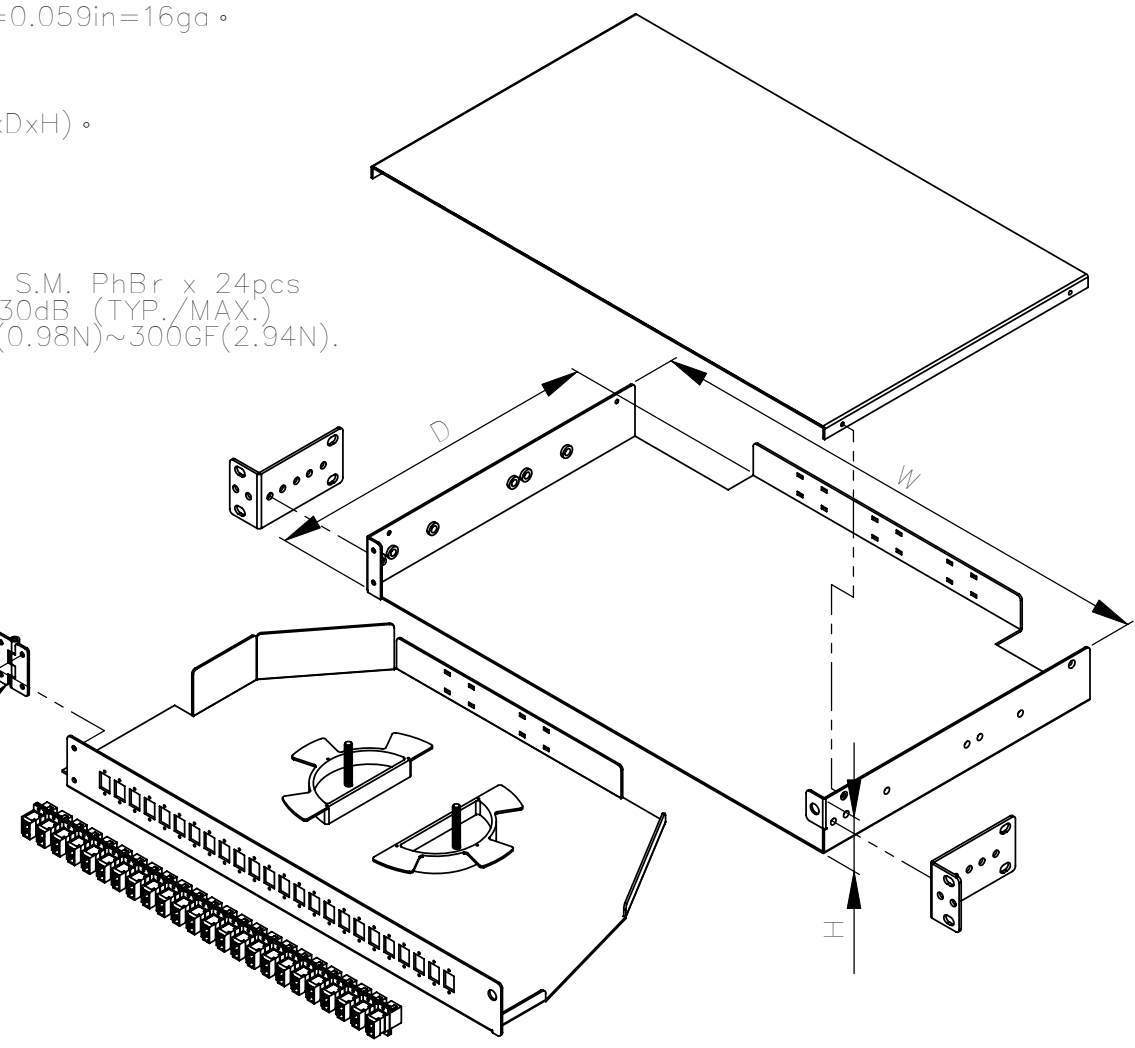

MATERIAL		SIGNATURE	DATE	Another quality product from BLACK BOX <small>724-746-5100 • www.blackbox.com</small>
QUANTITY		LU	2010/11/02	
		PROJECT ENGINEER	LU	DWG. NAME
		CHECKED	LIU	24C RACK MOUNT D.BOX-ASSEMBLY WITH LC ADAPTER SC FOOTPRINT
		APPROVED	CHANG	SIZE
		DRAWING MANAGER	CHUNG	C
			2010/11/02	DWG. NO.
				JPM385A
				REV.
				A
				SCALE : N/A
				2010/11/02 SHEET 1 OF 1