

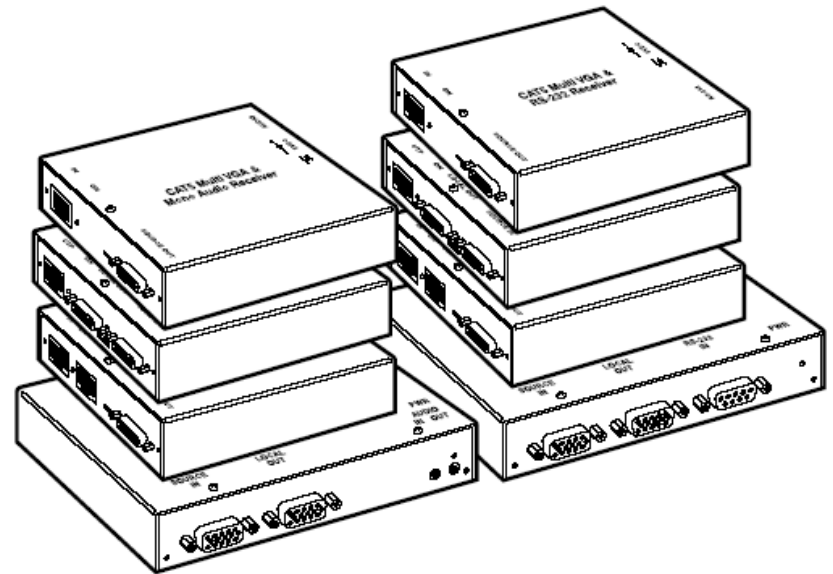

CAT5 Multi Video System (Component Video and SPDIF Audio)



**FEDERAL COMMUNICATIONS COMMISSION
AND
INDUSTRY CANADA
RADIO FREQUENCY INTERFERENCE STATEMENTS**

This equipment generates, uses, and can radiate radio-frequency energy, and if not installed and used properly, that is, in strict accordance with the manufacturer's instructions, may cause interference to radio communication. It has been tested and found to comply with the limits for a Class A computing device in accordance with the specifications in Subpart B of Part 15 of FCC rules, which are designed to provide reasonable protection against such interference when the equipment is operated in a commercial environment. Operation of this equipment in a residential area is likely to cause interference, in which case the user at his own expense will be required to take whatever measures may be necessary to correct the interference.

Changes or modifications not expressly approved by the party responsible for compliance could void the user's authority to operate the equipment.

This digital apparatus does not exceed the Class A limits for radio noise emission from digital apparatus set out in the Radio Interference Regulation of Industry Canada.

Le présent appareil numérique n'émet pas de bruits radioélectriques dépassant les limites applicables aux appareils numériques de la classe A prescrites dans le

Règlement sur le brouillage radioélectrique publié par Industrie Canada.

EUROPEAN UNION DECLARATION OF CONFORMITY

The manufacturer declares that this product meets the requirements of EU Directive 89/336/EEC.

**NORMAS OFICIALES MEXICANAS (NOM)
ELECTRICAL SAFETY STATEMENT
INSTRUCCIONES DE SEGURIDAD**

1. Todas las instrucciones de seguridad y operación deberán ser leídas antes de que el aparato eléctrico sea operado.
2. Las instrucciones de seguridad y operación deberán ser guardadas para referencia futura.
3. Todas las advertencias en el aparato eléctrico y en sus instrucciones de operación deben ser respetadas.
4. Todas las instrucciones de operación y uso deben ser seguidas.
5. El aparato eléctrico no deberá ser usado cerca del agua—por ejemplo, cerca de la tina de baño, lavabo, sótano mojado o cerca de una alberca, etc..
6. El aparato eléctrico debe ser usado únicamente con carritos o pedestales que sean recomendados por el fabricante.
7. El aparato eléctrico debe ser montado a la pared o al techo sólo como sea recomendado por el fabricante.
8. Servicio—El usuario no debe intentar dar servicio al equipo eléctrico más allá a lo descrito en las instrucciones de operación. Todo otro servicio deberá ser referido a personal de servicio calificado.
9. El aparato eléctrico debe ser situado de tal manera que su posición no interfiera su uso. La colocación del aparato eléctrico sobre una cama, sofá, alfombra o superficie similar puede bloquea la ventilación, no se debe colocar en libreros o gabinetes que impidan el flujo de aire por los orificios de ventilación.
10. El equipo eléctrico deber ser situado fuera del alcance de fuentes de calor como radiadores, registros de calor, estufas u otros aparatos (incluyendo amplificadores) que producen calor.
11. El aparato eléctrico deberá ser connectado a una fuente de poder sólo del tipo descrito en el instructivo de operación, o como se indique en el aparato.

12. Precaución debe ser tomada de tal manera que la tierra física y la polarización del equipo no sea eliminada.
13. Los cables de la fuente de poder deben ser guiados de tal manera que no sean pisados ni pellizcados por objetos colocados sobre o contra ellos, poniendo particular atención a los contactos y receptáculos donde salen del aparato.
14. El equipo eléctrico debe ser limpiado únicamente de acuerdo a las recomendaciones del fabricante.
15. En caso de existir, una antena externa deberá ser localizada lejos de las líneas de energía.
16. El cable de corriente deberá ser desconectado del cuando el equipo no sea usado por un largo periodo de tiempo.
17. Cuidado debe ser tomado de tal manera que objetos líquidos no sean derramados sobre la cubierta u orificios de ventilación.
18. Servicio por personal calificado deberá ser provisto cuando:
 - A: El cable de poder o el contacto ha sido dañado; u
 - B: Objetos han caído o líquido ha sido derramado dentro del aparato; o
 - C: El aparato ha sido expuesto a la lluvia; o
 - D: El aparato parece no operar normalmente o muestra un cambio en su desempeño; o
 - E: El aparato ha sido tirado o su cubierta ha sido dañada.

TRADEMARKS USED IN THIS MANUAL

Any trademarks mentioned in this manual are acknowledged to be the property of the trademark owners.

Contents

Chapter	Page
1. Specifications.....	5
2. Introduction	7
2.1 Overview.....	7
2.2 Package Contents	8
2.3 Equipment You May Also Need.....	8
2.4 Compatible Cabling	8
3. Setup and Installation.....	9
3.1 Cabling Considerations.....	9
3.2 Making the Connections.....	9
3.2.1 Connections and Setup in General	9
3.2.2 Connections on the Single-Port Video/Audio (AC1045A—AC1047A).....	10
3.2.3 Connections on the Quad Hub Video/Audio Transmitter (AC1046A)	11
3.2.4 Connections on the Dual Daisychainable VGA/Audio Receiver (AC1048A)	12
3.2.5 A Typical Single-Port Transmitter–Receiver Application	13
3.2.6 A Typical Quad Hub Transmitter–Receiver Application.....	14
4. Troubleshooting.....	15
4.1 Common Problems	15
4.2 Calling Black Box	15
4.3 Shipping and Packaging	15
Appendix A. Cabling Pinouts.....	16
Appendix B. Setting Sync Signal Output Termination.....	17
Appendix C. Rackmounting Units	18

1. Specifications

- Cable Required:** Between transmitter and receiver(s): Category 5 shielded or unshielded twisted pair (STP or UTP), though STP is virtually never necessary
- Compliance:** CE; FCC Class A, IC Class/classe A
- Video Support:** RGB component (YUV, YPrPb)
- Resolution and Refresh Rate:** 2048 x 1536 @ 70 Hz, SD and HDTV formats (480i, 480p, 525p, 720p, 1080i, 1080p)
- Transmission:** Transparent to users (automatic, no delay)
- Required Source Impedance:** Video OUT: 75 ohms;
Audio models: Audio OUT (if any): 600 ohms maximum
- Required Destination Impedance:** Video IN: 75 ohms;
SPDIF Audio IN: 75 ohms
- Bandwidth:** Video (3 dB): DC to 8 MHz
- Maximum Differential Input and Output:** Video: 0.55 volts peak-to-peak;
Audio: 0.5 volts peak-to-peak
- Differential Insertion Loss:** Video: 0 dB maximum at 4 MHz;
Audio: 1 dB maximum at 1 MHz
- Audio Characteristics:** Channels: full SPDIF digital audio

- Maximum Distance:** Total end to end, from source device to farthest destination device, over good CAT5 cable (assuming A/V source outputs signal at normal strength):
Up to 500 ft. (137.2 m) all resolutions
- Connectors:** AC1045A: (1) 4 captive screw, (1) RJ-45, (2) HD15 F;
AC1046A: (2) 3.5-mm, (4) RJ-45, (2) HD15 F;
AC1047A-R2: (1) 4 captive screw, (1) RJ-45, (1) HD15 F;
AC1048A-R2: (1) 4 captive screw, (2) RJ-45, (1) HD15 F;
All: (1) power inlet
- Temperature Tolerance:** Operating: 32 to 104°F (0 to 40°C);
Storage: -4 to +140°F (-20 to +60°C)
- Humidity Tolerance:** Up to 80% noncondensing
- Enclosure:** Steel
- Power:** From utility-power (mains) outlet to power inlet, through detachable external power supply: Input: 100 to 250 VAC @ 50 or 60 Hz (autosensing);
Output: +5 VDC;
Consumption: 5 watts maximum
- Size:** AC1045A:
1.2"H x 4.1"W x 4.3"D (3.1 x 10.4 x 10.9 cm);
AC1047-R2A, AC1048-R2:
1.2"H x 4.1"W x 5.5"D (3.1 x 10.4 x 14.0 cm)
AC1046A: 1.2"H x 5.6"W x 4.5"D
(3.1 x 14.2 x 11.4 cm)
- Weight:** AC1045A: 0.8 lb. (0.4 kg);
AC1047A-R2, AC1048A-R2: 1.0 lb. (0.45 kg);
AC1046A: 1.4 lb. (0.6 kg);

2. Introduction

2.1 Overview

The CAT5 Multi Video System extends SD and HDTV video signals over ordinary Category 5 cable. All models use a transmitter-to-receiver setup. They can be used as video splitters as well as video extenders.

This manual covers CAT5 Multi Video System Transmitters and Receivers with SDPIF Audio (AC1045A–AC1048A-R2). Their respective Rackmount Kits (AC1008–AC1012) are discussed in **Appendix C**.

Among the transmitters available for video/audio models are single-port models and four-port (quad hub) versions. The quad hub transmitter is used to distribute the same signal to multiple display devices. Setup and cabling are the same as the single-port transmitters.

CAT5 Multi Video System receivers are available with single or dual daisychainable connections. The dual daisychainable receiver is used when the same signal is distributed to multiple display devices across a single CAT5 cable in a daisychain or loop-through fashion. Setup and cabling are the same as the single-port receiver.

WARNING

This equipment is not intended for, nor does it support, distribution through an Ethernet network. Do not connect these devices to any sort of networking or telecommunications equipment!

2.2 Package Contents

You should have received the following when ordering a CAT5 Multi Video System receiver:

- The transmitter or receiver.
- An adapter cable with 3 RCA connectors on one end and one 15HD connector on the other end.
- External power supply (100–250 VAC, 50–60 Hz, autosensing) with cord.
- This manual.

2.3 Equipment You May Also Need

- Audio cable with RCA jacks.
- CAT5 cable.
- For the single-port audio models, an audio splitter.

2.4 Compatible Cabling

CAT5 cabling for the CAT5 Multi Video System must be pinned to the TIA-EIA T568B wiring specification. We also highly recommend that all CAT5 cables be pre-terminated and tested. Cables terminated on-site or in an existing infrastructure should be tested before use to ensure compliance with the TIA-EIA T568B specification. Using incorrectly terminated CAT5 cables can damage the CAT5 Multi Video System.

3. Setup and Installation

3.1 Cabling Considerations

- We recommend mounting and connecting all cabling to the CAT5 Multi Video System components before applying power.
- Makes sure that the CAT5 cable you intend to use has been tested to comply with the TIA/EIA 568B wiring specification.

3.2 Making the Connections

3.2.1 CONNECTIONS AND SETUP IN GENERAL

This section contains figures showing connections with the specific CAT5 Multi Video System models. In general, however, the connection and setup procedure at both transmitter and receiver ends is as follows:

At the transmitter end:

1. Connect the source video to the CAT5 Multi Video System transmitter video input port, which is an HD15 connector labeled SOURCE IN.
2. If desired, attach a local monitor via the local monitor port to LOCAL OUT.

NOTE

The single-port units with audio have a single audio input. So, for audio capabilities on the attached monitor, you'll need an audio splitter.

3. Make your audio or serial connections.
For models AC1045A, AC1047A-R2, AC1048A-R2: Connect the audio input to the AUDIO connector Pins 1 (+), 2 (-)
For model AC1046A: Connect the audio input to the 3.5mm AUDIO connector

4. Connect the CAT5 cable to the transmitter.

5. Apply power on the transmitter. The LED should light and, if there's a local monitor attached, a video image should appear on the monitor's screen.

At the receiver end:

1. Connect the SOURCE OUT HD15 connector to the display unit, and attach any audio or serial connections depending on the model of CAT5 Multi VGA System (see Sections 3.3.2 through 3.3.5 for model-specific connections).
2. Make sure that the CAT5 cable connection(s) from the transmitter are secure.
3. Apply power. The LED should light and video should appear on the display (make sure display is powered ON).
4. For video clarity, adjust the compensation knob which optimizes the image for the length of CAT5 cable used.

If there are any problems at either end, see **Chapter 4**.

3.2.2 CONNECTIONS ON THE SINGLE-PORT Video/Audio (AC1045A)

The single-port units with audio (AC1045A, AC1047A-R2) support video and audio signals over CAT5 cable. The audio signal is SPDIF audio, and powered speakers are required. Note that there's a single connection for audio input. If you use a local station, you'll need an audio splitter for that jack. (For more information, call Technical Support.) You can also use the transmitters and receivers to make video-only connections without mono audio.

Figure 3-1 shows the Single-Port CAT5 Multi Video System with Audio Transmitter connections, and Figure 3-2 shows the receiver connections.



Figure 3-1. Transmitter connections on the AC1045A.

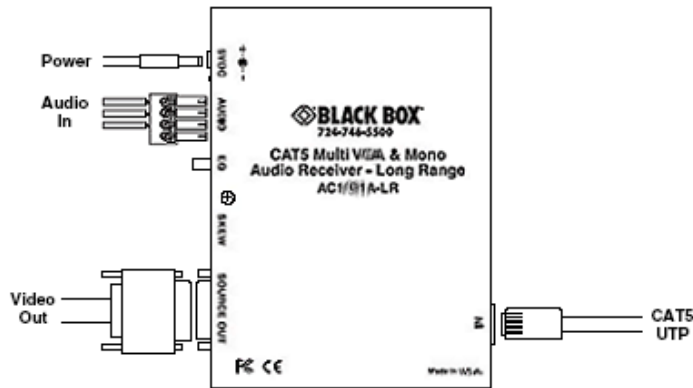

Figure 3-2. Receiver connections on the AC1047A-R2.

3.2.3 CONNECTIONS ON THE QUAD HUB Video/AUDIO TRANSMITTER (AC1046A)

The quad hub (four-port) transmitter is used when the same signal is distributed to multiple display devices. You set it up and cable it the same as you would with the single-port transmitter. Figure 3-3 shows how connections are made on the audio quad hub (AC1046A) version.

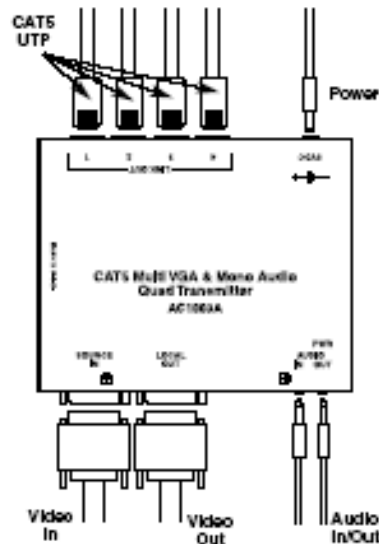

Figure 3-3. Quad hub connections on the AC1046A.

3.2.4 CONNECTIONS ON THE DUAL DAISYCHAINABLE Video/AUDIO RECEIVER (AC1048A-R2)

The dual daisychainable receiver is used when the same signal is distributed to multiple display devices on a single CAT5 cable in a daisychain or loop-through fashion.

Setup and cabling are the same as the single-port receiver, but the dual daisychainable model has an additional RJ-45 connector for linking to another dual daisychainable receiver or single-port receiver.

Figure 3-4 shows how connections are made on the dual daisychainable receiver with audio.

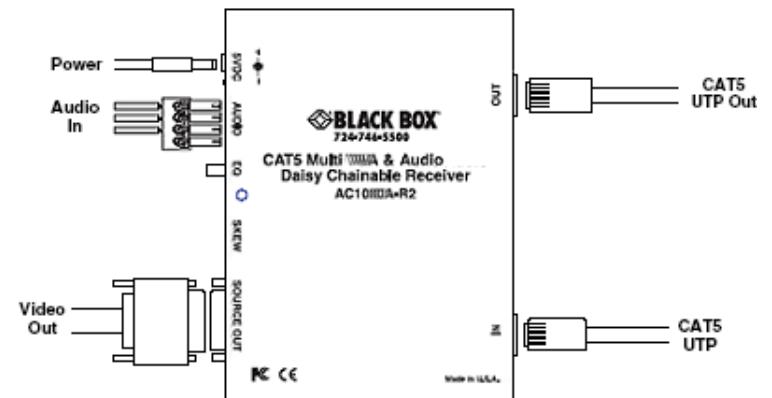

Figure 3-4. Dual daisychainable receiver connections on the AC1048A-R2.

3.2.5 A TYPICAL SINGLE-PORT TRANSMITTER-RECEIVER APPLICATION

Figure 3-5 shows a typical application in which the single-unit transmitter (AC1045A) is connected over CAT5 to a single-unit receiver (AC1047A-R2).

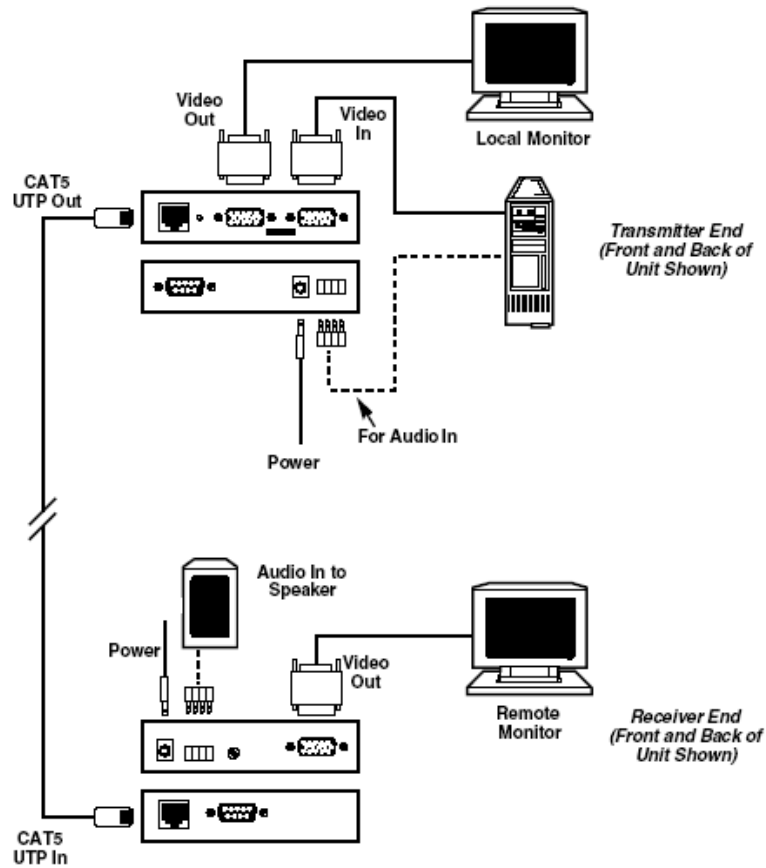

Figure 3-5. Transmitter to receiver connections.

3.2.6 A TYPICAL QUAD HUB TRANSMITTER-RECEIVER APPLICATION

Figure 3-6 shows an application in which a Quad Hub CAT5 Multi VGA System Transmitter is linked to four Single-Port CAT5 Multi VGA System Transmitters.

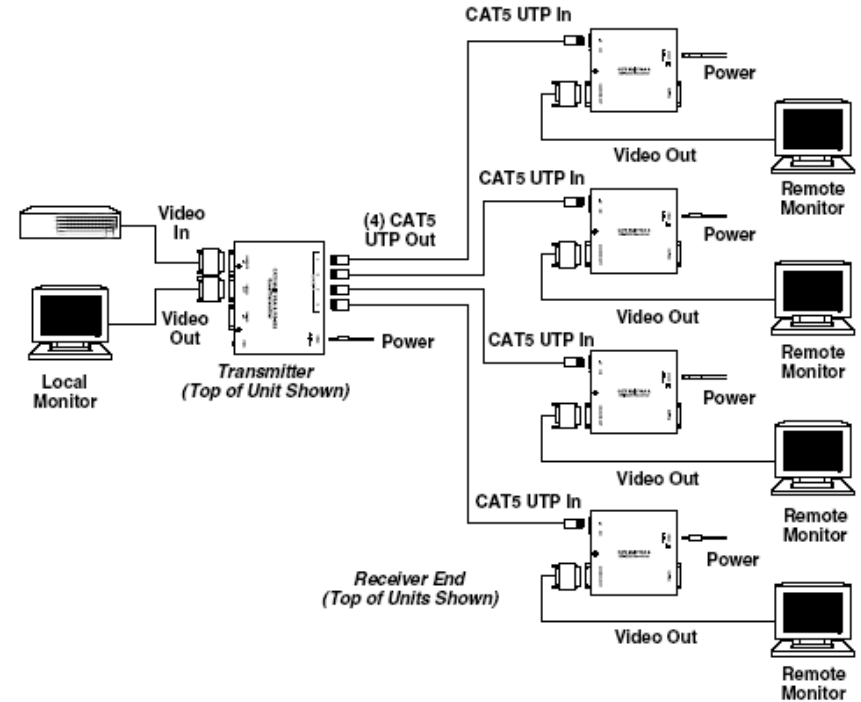

Figure 3-6. Quad hub to receiver connections.

4. Troubleshooting

4.1. Common Problems

In most cases, nearly every issue with the CAT5 Multi Video System can be resolved by checking the CAT5 termination and making sure that it's pinned to the TIA/EIA 568B wiring specification. However, there may be other problems that cause the system to not perform as it's designed. Below are solutions to the most common installation errors.

Problem: No video signal at the transmitter local port or at the receiver.
Solution:

- Check that both units are powered.
- Make sure the CAT5 cable is terminated correctly per the TIA/EIA 568B wiring specification.
- Is the display device powered on and functioning?
 In some cases, the video termination may be mismatched. The transmitters and receivers ship with 75-ohm termination as the default. To disable termination, see **Appendix B**.

Problem: Video signal is poor.
Solution:

- Have all receiver settings been finished .
- Check all cable connections.
- The video signal's refresh rate may be set too high. Reset to a lower refresh rate in your monitor-configuration menu.
- There may be a delay skew issue. Call Technical Support.

Problem: Audio is poor.
Solution:

- Powered speakers are required. Make sure speaker power is ON.
- Check input source levels from the source device. Make sure the audio source is not overdriven or underdriven.

4.2 Calling Black Box

If you determine that your CAT5 Multi Video System is malfunctioning, do not attempt to alter or repair it. It contains no user-serviceable parts. Contact Black Box at 724-746-5500. Before you do, make a record of the history of the problem. We will be able to provide more efficient and accurate assistance if you have a complete description, including:

- the nature and duration of the problem.
- when the problem occurs.
- the components involved in the problem.
- any particular application that, when used, appears to create the problem or make it worse.

4.3 Shipping and Packaging

If you need to transport or ship your CAT5 Multi Video System:

- Package it carefully. We recommend that you use the original container.
- If you are shipping the CAT5 Multi Video System for repair, make sure you include everything that came in the original package. Before you ship, contact Black Box to get a Return Authorization (RA) number.

Appendix A. Cabling Pinouts

Table A-1. HD15 video connector.

Pin	RGB	YUV	
1	V +	Pr+	
2	Y+	Y+	
3	U+	Pb+	
4	—		
5	—		
6	V-	Pr-	
7	Y-	Y-	
8	U-	Pb-	
9	—		
10			
11			
12			
13			
14			
15			

Table A-2. AUDIO connector

<u>PIN</u>	<u>Audio</u>
Pin 1	SPDIF Signal +
Pin 2	SPDIF Signal -
Pin 3	-
Pin 4	-

Appendix B. Setting Sync Signal Output Termination

In some cases, it may be necessary to disable the 75-ohm termination of the video outputs on the CAT5 Multi Video System units. This can be done by opening the case of each unit and installing jumpers on the circuit board. The settings disable/enable the 75-ohm termination on individual units. For instance, changing a transmitter termination affects the local monitor port only; it doesn't affect the receivers. Conversely, changing a receiver affects the output port of the receiver, not the transmitter. The following diagrams show the jumper locations for each type of assembly.

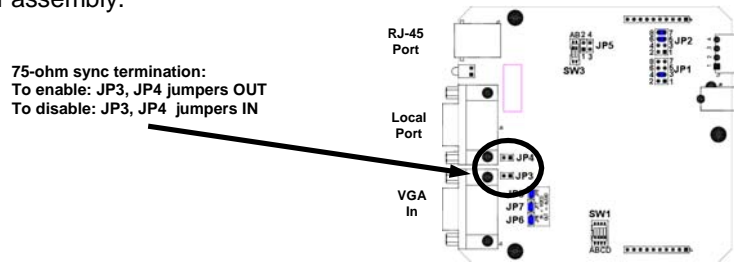

75-ohm sync termination:
To enable: JP3, JP4 jumpers OUT
To disable: JP3, JP4 jumpers IN

Figure B-1. 1-port transmitter.

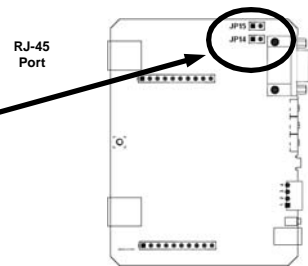

75-ohm sync termination:
To enable: Both jumpers OUT
To disable: Both jumpers IN

Figure B-2. 1-port and dual daisychainable receiver.

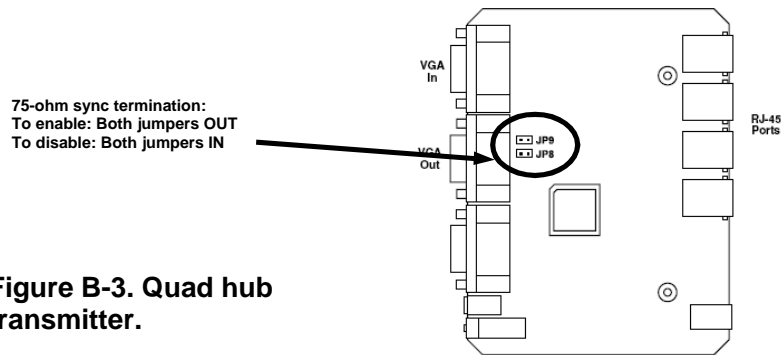

75-ohm sync termination:
To enable: Both jumpers OUT
To disable: Both jumpers IN

Figure B-3. Quad hub transmitter.

Appendix C. Rackmounting Units

The Rackmount Kits include brackets for mounting a single transmitter, single receiver, or a single dual daisychainable receiver. Figure C-1 shows the 1-Unit Rackmount Bracket (AC1008), which can be used to mount a single CAT5 Multi Video System unit on a wall. Figure C-2 shows the 4-Unit Rackmount Bracket (AC1009), which holds four units in a 19" x 1U rack.

Not shown are brackets for 8 units and brackets for quad hub transmitters. The 8-Unit Rackmount Bracket (AC1010) holds the mounted units like the 4-Unit Rackmount Bracket (AC1009) but is 2U high instead of 1U high, stacking 4 slots directly above 4 slots. The 3-Unit Quad Hub Transmitter Bracket (AC1011) is like the AC1009 but holds 3 units instead of 4 in a 19" wide x 1U high panel. The 6-Unit Quad Hub Transmitter Bracket (AC1012) is like the AC1011 but occupies 2U of space instead of 1U in a 19" rack, stacking 3 quad hub transmitters atop 3 quad hub transmitters.

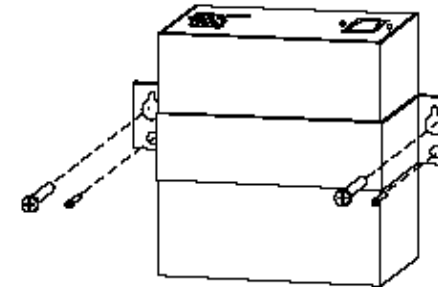

Figure C-1. Mounting with the AC1008 kit.

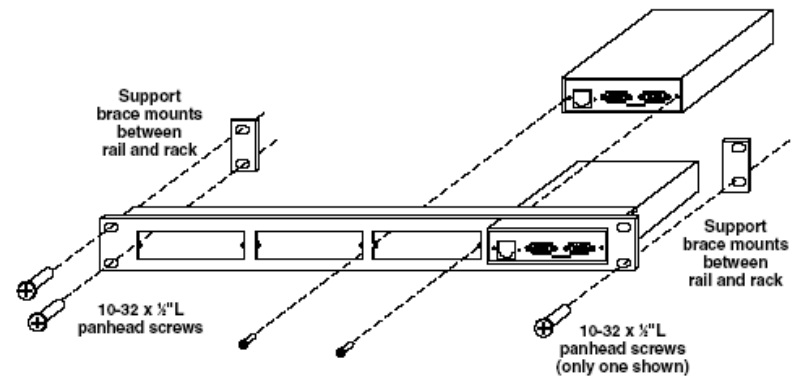

Figure C-2. Mounting with the AC1009 kit.

