



CAT5 Multi VGA System (VGA and Audio)



**CUSTOMER
SUPPORT
INFORMATION**

Order toll-free in the U.S.: Call 877-877-BBOX (outside U.S. call 724-746-5500)
FREE technical support 24 hours a day, 7 days a week: Call 724-746-5500 or fax 724-746-0746
Mailing address: **Black Box Corporation**, 1000 Park Drive, Lawrence, PA 15055-1018
Web site: www.blackbox.com • E-mail: info@blackbox.com

||
—

||
—

|

—
|

—
|

FCC/IC RFI STATEMENTS, EU DECLARATION OF CONFORMITY

FEDERAL COMMUNICATIONS COMMISSION AND INDUSTRY CANADA RADIO FREQUENCY INTERFERENCE STATEMENTS

This equipment generates, uses, and can radiate radio-frequency energy, and if not installed and used properly, that is, in strict accordance with the manufacturer's instructions, may cause interference to radio communication. It has been tested and found to comply with the limits for a Class A computing device in accordance with the specifications in Subpart B of Part 15 of FCC rules, which are designed to provide reasonable protection against such interference when the equipment is operated in a commercial environment. Operation of this equipment in a residential area is likely to cause interference, in which case the user at his own expense will be required to take whatever measures may be necessary to correct the interference.

Changes or modifications not expressly approved by the party responsible for compliance could void the user's authority to operate the equipment.

This digital apparatus does not exceed the Class A limits for radio noise emission from digital apparatus set out in the Radio Interference Regulation of Industry Canada.

Le présent appareil numérique n'émet pas de bruits radioélectriques dépassant les limites applicables aux appareils numériques de la classe A prescrites dans le

Règlement sur le brouillage radioélectrique publié par Industrie Canada.



EUROPEAN UNION DECLARATION OF CONFORMITY

The manufacturer declares that this product meets the requirements of EU Directive 89/336/EEC.

NORMAS OFICIALES MEXICANAS (NOM) ELECTRICAL SAFETY STATEMENT INSTRUCCIONES DE SEGURIDAD

1. Todas las instrucciones de seguridad y operación deberán ser leídas antes de que el aparato eléctrico sea operado.
2. Las instrucciones de seguridad y operación deberán ser guardadas para referencia futura.
3. Todas las advertencias en el aparato eléctrico y en sus instrucciones de operación deben ser respetadas.
4. Todas las instrucciones de operación y uso deben ser seguidas.
5. El aparato eléctrico no deberá ser usado cerca del agua—por ejemplo, cerca de la tina de baño, lavabo, sótano mojado o cerca de una alberca, etc..
6. El aparato eléctrico debe ser usado únicamente con carritos o pedestales que sean recomendados por el fabricante.
7. El aparato eléctrico debe ser montado a la pared o al techo sólo como sea recomendado por el fabricante.
8. Servicio—El usuario no debe intentar dar servicio al equipo eléctrico más allá a lo descrito en las instrucciones de operación. Todo otro servicio deberá ser referido a personal de servicio calificado.
9. El aparato eléctrico debe ser situado de tal manera que su posición no interfiera su uso. La colocación del aparato eléctrico sobre una cama, sofá, alfombra o superficie similar puede bloquea la ventilación, no se debe colocar en libreros o gabinetes que impidan el flujo de aire por los orificios de ventilación.
10. El equipo eléctrico deber ser situado fuera del alcance de fuentes de calor como radiadores, registros de calor, estufas u otros aparatos (incluyendo amplificadores) que producen calor.
11. El aparato eléctrico deberá ser conectado a una fuente de poder sólo del tipo descrito en el instructivo de operación, o como se indique en el aparato.
12. Precaución debe ser tomada de tal manera que la tierra física y la polarización del equipo no sea eliminada.
13. Los cables de la fuente de poder deben ser guiados de tal manera que no sean pisados ni pellizcados por objetos colocados sobre o contra ellos, poniendo particular atención a los contactos y receptáculos donde salen del aparato.
14. El equipo eléctrico debe ser limpiado únicamente de acuerdo a las recomendaciones del fabricante.
15. En caso de existir, una antena externa deberá ser localizada lejos de las líneas de energía.
16. El cable de corriente deberá ser desconectado del cuando el equipo no sea usado por un largo periodo de tiempo.
17. Cuidado debe ser tomado de tal manera que objetos líquidos no sean derramados sobre la cubierta u orificios de ventilación.
18. Servicio por personal calificado deberá ser provisto cuando:
A: El cable de poder o el contacto ha sido dañado; u
B: Objetos han caído o líquido ha sido derramado dentro del aparato; o
C: El aparato ha sido expuesto a la lluvia; o
D: El aparato parece no operar normalmente o muestra un cambio en su desempeño; o
E: El aparato ha sido tirado o su cubierta ha sido dañada.

Contents

Chapter	Page
1. Specifications.....	3
2. Introduction	5
2.1 Overview.....	5
2.2 Package Contents	6
2.3 Equipment You May Also Need.....	6
2.4 Compatible Cabling	6
3. Setup and Installation.....	7
3.1 Making the Connections.....	7
3.1.1 Connections and Setup in General	7
3.1.2 Transmitter Connections.....	8
3.1.3 Receiver Connections.....	9
3.2 Receiver Adjustments.....	11
3.2.1 AC1001A-R2.....	11
3.2.2 AC1002A-R3, AC1013A-R2, AC1014A-R2.....	12
3.2.3 Skew Compensation.....	13
3.3 Typical Applications.....	14
4. Troubleshooting.....	15
4.1 Common Problems	15
4.2 Calling Black Box	16
4.3 Shipping and Packaging	16
Appendix A. Cabling Pinouts.....	17
Appendix B. DC Restoration Setting	19
Appendix C. Receiver Video Settings.....	20
Appendix D. Rackmounting Units	21
Appendix E. Daisy Chain Termination.....	22
Appendix F. DDC Modes.....	23
Appendix G. Sync Modes.....	24

1. Specifications

Cable Required: CatX (5/5e/6) UTP

Compliance: CE; FCC Class A, IC Class/classe A

Video Support: RGBHV, RGB, YUV, S-Video, composite, 75 ohm.

Audio Support: 2 Channels Right/Left Summed (mono output)

Resolution and (receiver dependent)

Refresh Rate: AC1001A-R2 1366x768, 720P
 AC1002A-R3 1920x1080, 1080P;
 AC1211A 1920x1080, 1080P;
 AC1013A-R2 1920x1080, 1080P;
 AC1014A-R2 1920x1080, 1080P;
 See the **Maximum Distance** specification

Maximum (receiver dependent)

Distance: AC1001A-R2 500 ft (152 m)
 AC1002A-R3 600 ft (183 m)
 AC1211A 600 ft (183 m)
 AC1013A-R3 1200 ft (366 m)
 AC1014A-R2 2000 ft (610 m)

Skew (included for models below only).

Compensation: AC1211A Included
 AC1013A-R2 Included
 AC1014A-R2 Included

Power: All models except below: +5 VDC (5W max)
 AC1014A-R2 +12VDC (6W max)

Temperature

Tolerance: Operating: 32 to 104°F (0 to 40°C);
 Storage: -4 to +140°F (-20 to +60°C)

Humidity

Tolerance: Up to 80% noncondensing

Enclosure: Steel

CAT5 MULTI VGA SYSTEM

Connectors:	Transmitters:
	AC1000A-R3: (1) 4 captive screw, (1) RJ-45, (2) HD15 F; AC1003A: (2) 3.5-mm, (4) RJ-45, (2) HD15 F;
	Receivers:
	AC1001A-R2: (1) 3.5-mm, (1) RJ-45, (1) HD15 F; AC1002A-R3: (1) 4 captive screw, (2) RJ-45, (1) HD15 F; AC1211A: (1) 4 captive screw, (2) RJ-45, (1) HD15 F; AC1013A-R2: (1) 4 captive screw, (2) RJ-45, (2) HD15 F; AC1014A-R2: (1) 4 captive screw, (2) RJ-45, (1) HD15 F;
	All: (1) power inlet
Size:	Transmitters:
	AC1000A-R3: 1.2"H x 4.1"W x 4.3"D (3.1 x 10.4 x 10.9 cm) AC1003A: 1.2"H x 5.6"W x 4.5"D (3.1 x 14.2 x 11.4 cm)
	Receivers:
	AC1001A-R2: 1.0"H x 3.1" W x 3.7" D (2.2 x 7.9 x 9.5 cm) AC1002A-R3: 1.2"H x 5.5"W x 3.6"D (3.0 x 14.0 x 9.2 cm) AC1211A: 1.2"H x 5.5"W x 3.6"D (3.0 x 14.0 x 9.2 cm) AC1013A-R2: 1.2"H x 5.5"W x 3.6"D (3.0 x 14.0 x 9.2 cm) AC1014A-R2: 1.2"H x 5.6"W x 6.2"D (3.0 x 14.2 x 15.7 cm)
Weight:	Transmitters:
	AC1000A-R3: 0.8 lb. (0.4 kg); AC1003A: 1.4 lb. (0.6 kg);
	Receivers:
	AC1001A-R2: 0.6 lb. (0.3 kg); AC1002A-R3: 1.0 lb. (0.5 kg); AC1211A: 1.0 lb. (0.5 kg); AC1013A-R2: 1.0 lb. (0.5 kg); AC1014A-R2: 2.0 lb. (0.9 kg);

2. Introduction

2.1 Overview

The CAT5 Multi VGA System for Video and Audio extends video and audio signals over ordinary Category 5 cable. All models support RGBHV, RGB, and VGA video, and they use a transmitter-to-receiver setup.

This manual covers the following CAT5 Multi VGA System Transmitters and Receivers:

Transmitters:

AC1000A-R3	Single port transmitter
AC1003A	4 port Quad hub transmitter

Receivers

AC1001A-R2	500 ft range
AC1002A-R3	600 ft range, daisy chainable
AC1211A	600 ft range, daisy chainable (incl skew comp)
AC1013A-R2	1200 ft range, daisy chainable (incl skew comp)
AC1014A-R2	2000 ft range, daisy chainable (incl skew comp)

The video/audio models enable you to broadcast line-level mono audio, along with video from your computer, to as many as 100 computer monitors to various cable distances depending upon receiver in use.

Among the transmitters available for both video/audio models are single-port models and four-port (quad hub) versions. The quad hub transmitter is used to distribute the same signal to multiple display devices.

CAT5 Multi VGA System receivers are available with single or dual daisychainable connections. The dual daisychainable receiver is used when the same signal is distributed to multiple display devices across a single CAT5 cable in a daisychain or loop-through fashion. Setup and cabling are the same as the single-port receiver.

You can daisy chain within the rated distance of the receiver. For example, an AC1002A-R3 can be daisy chained within 600 ft of the transmitter. It is possible to daisy chain out of a shorter range receiver into a longer range receiver. For example, when daisy chaining over 600 ft, an AC1002A-R3 can be daisy chained to an AC1013A-R2 over 600 ft. up to 1200 ft.

A maximum of 12 units may be daisy chained.

CAT5 MULTI VGA SYSTEM

WARNING

This equipment is not intended for, nor does it support, distribution through an Ethernet network. Do not connect these devices to any sort of networking or telecommunications equipment!

2.2 Package Contents

You should have received the following when ordering a CAT5 Multi VGA System unit:

- The transmitter or receiver.
- External power supply (100–250 VAC, 50–60 Hz, autosensing) with cord.
- This manual.

2.3 Equipment You May Also Need

- Rackmount Brackets (see Appendix D)
- Audio cable
- Video cable
- CAT5 cable

2.4 Compatible Cabling

The CAT5 Multi VGA System products are compatible with Cat5/5e/6 data cabling as well as skew free CAT5/5e cabling manufactured for video applications. Note that some skew free Cat5 is specific to a particular vendor and is not compatible with these products. Please ensure any skew free CAT5 cable is non-proprietary prior to purchase/installation.

CAT6 cable, due to the manufacture method, can exhibit much greater skew than standard CAT5/5e and may require skew compensation beyond what the standard product offers.

CAT5/5e/6 cabling for the CAT5 Multi VGA Series must be pinned to the TIA-EIA T568B wiring specification (see Appendix A) We also highly recommend that all CAT5 cables be pre-terminated and tested. Cables terminated on-site or in an existing infrastructure should be tested before use to ensure compliance with the TIA-EIA T568B specification. Using incorrectly terminated CAT5 cables can damage the units.

3. Setup and Installation

3.1 Making the Connections

3.1.1 CONNECTIONS AND SETUP IN GENERAL

This section contains figures showing connections with the specific CAT5 Multi VGA System models. In general, however, the connection and setup procedure at both transmitter and receiver ends is as follows (see sections 3.1.2, 3.1.3 for typical connections and section 3.3 for typical applications):

At the transmitter end:

1. Connect the source video to the CAT5 Multi VGA System transmitter video input port, which is an HD15 connector labeled SOURCE IN.
2. If desired, attach a local monitor via the local monitor port to LOCAL OUT.
3. Make your audio connections.
Connect the audio input to the AUDIO connector Pins 1 (Left Audio +) , 2 (ground), 3 (Right Audio +) for the AC1000A-R3 or the 3.5mm audio jack for the AC1003A.
4. Connect the CAT5 cable to the transmitter.
5. Apply power on the transmitter. The LED should light and, if there's a local monitor attached, a video image should appear on the monitor's screen.

At the receiver end:

1. Connect the SOURCE OUT HD15 connector to the display unit, and attach any audio connections depending on the model of CAT5 Multi VGA System (see Sections 3.1.3 for model-specific connections).
2. Make sure that the CAT5 cable connection(s) from the transmitter are secure.
3. Apply power. The LED should light and video should appear on the display (make sure display is powered ON).
4. For video clarity, see Section 3.2 for individual receiver adjustments.

If there are any problems at either end, see **Chapter 4**.

CAT5 MULTI VGA SYSTEM

3.1.2 TRANSMITTER CONNECTIONS:

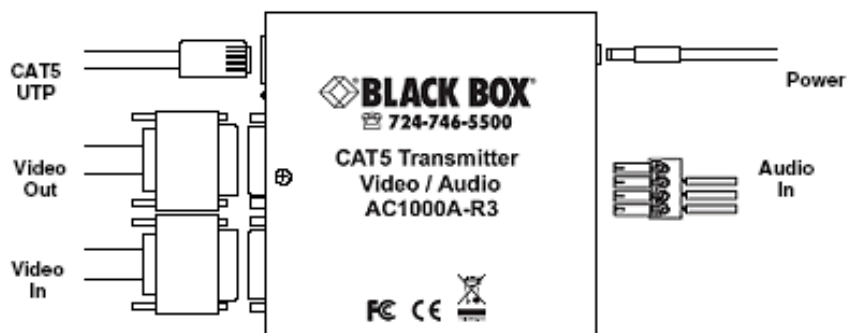

Figure 3-1. Transmitter connections on the AC1000A-R3.

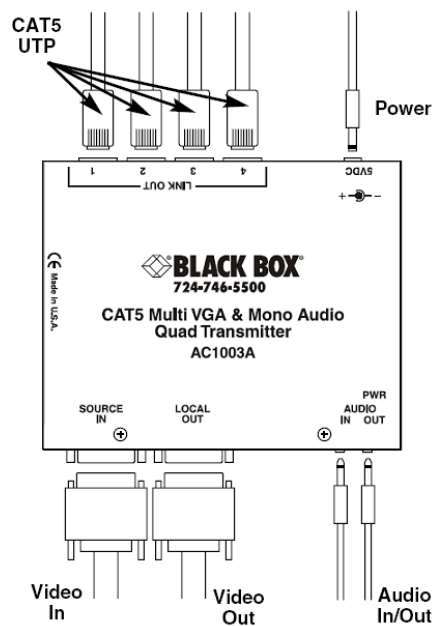

Figure 3-2. Quad hub connections on the AC1003A.

CHAPTER 3: Setup and Installation

3.1.3 RECEIVER CONNECTIONS:

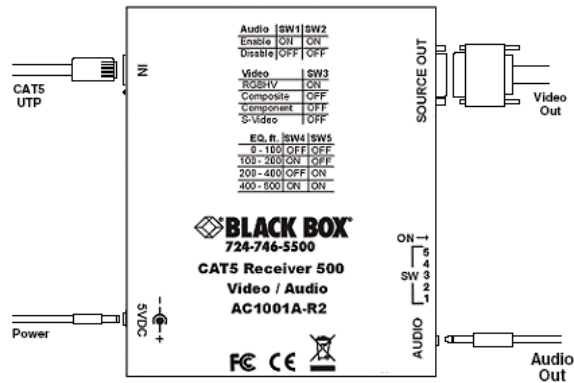

Figure 3-3. Receiver connections on the AC1001A-R2.

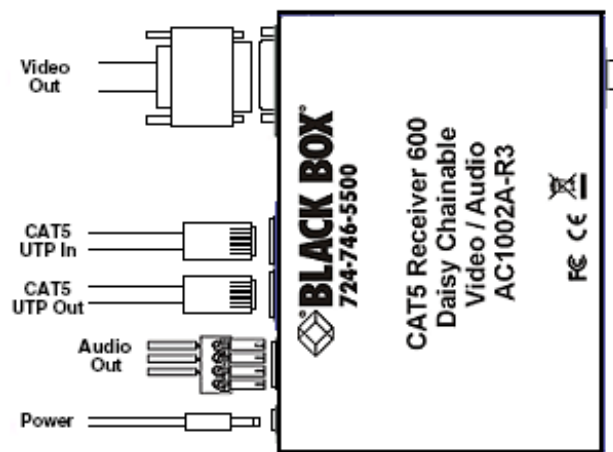

Figure 3-4. Receiver connections on the AC1002A-R3.

CAT5 MULTI VGA SYSTEM

3.1.3 RECEIVER CONNECTIONS:

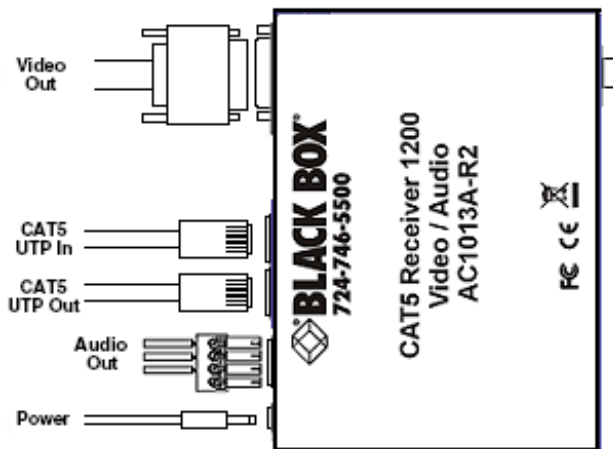

Figure 3-5. Receiver connections on the AC1013A-R2.



Figure 3-6. Receiver connections on the AC1014A-R2.

CHAPTER 3: Setup and Installation

3.2 RECEIVER ADJUSTMENTS:

This section details the tuning and adjustments for each receiver. The CAT5 Multi VGA system receivers have a single adjustment to compensate for different Cat5 cable lengths. This EQ process is easy and simple to do and must be done once unless the unit is moved to a different location.

Skew compensation is also shown—this does not apply to all receiver units.

3.2.1 AC1001A-R2 ADJUSTMENTS

The only adjustments required on the AC1001A-R2 receiver are the SW positions 4 and 5 which must be set to compensate for cable length. Using the table below as a guide, turn SW positions ON or OFF for best picture clarity (ON = down, OFF = up):

Cable distance EQ settings		
Cable Length	4	5
(0-125 Ft)	OFF	OFF
(125-250 Ft)	ON	OFF
(250-375 Ft)	OFF	ON
(375-500 Ft)	ON	ON

Table 3-1. AC1001A-R2 EQ adjustment.

CAT5 MULTI VGA SYSTEM

3.2.2 AC1002A-R3, AC1211A, AC1013A-R2, AC1014A-R2 ADJUSTMENTS

An image utility should be included with the receiver. If it cannot be located, contact Black Box Technical Support.

NOTE: TURN KNOB SLOWLY DURING ADJUSTMENT PROCEDURE. Turning too fast may result in missing the proper EQ setting resulting in picture loss.

To Reset EQ and Skew values to 0, remove power, push and hold EQ/Skew Knob in and re-apply power.

1. Push EQ/Skew knob in once so that the R/G/B LED is white (AC1002A-R3, AC1211A, AC1013A-R2) or all three RGB LED's are on (AC1014A-R2).
2. Turn the EQ/Skew knob clockwise until the shadow next to the black box just disappears. The brightness in the white area should be the same as the white area above and below the black box. The Cable Length LEDs will turn on for indicated cable distances (AC1014A-R2). Starting from zero feet to 600/1200/2000 may take some time. Please continue turning the knob for best picture quality.
3. Press and release EQ/Skew knob until the R/G/B LED (AC1002A-R3, AC1211A, AC1013A-R2) is off, or all three RGB LED's are off (AC1014A-R2).

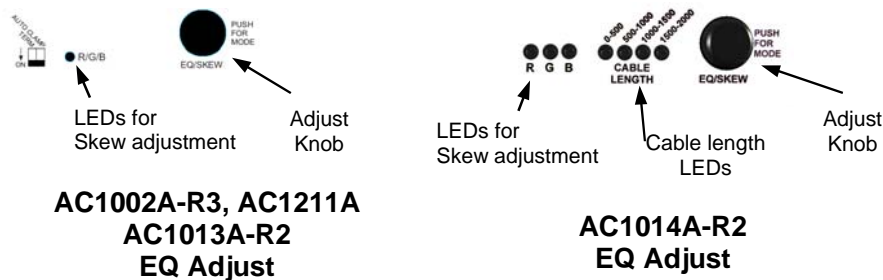

Distance Compensation Setting Utility

Adjust Cable Compensation control to obtain a minimum shadowing effect in the white area to the right of the black window

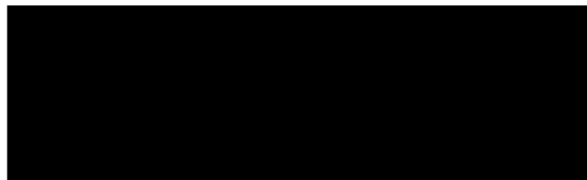

Figure 3-7. Image Adjustment Utility.

CHAPTER 3: Setup and Installation

3.2.3 Skew Compensation Settings

The AC1211A, AC1013A-R2, AC1014A-R2 receivers are available with an optional skew compensation module to adjust for signal timing differences due to differing pair lengths within the CAT5 cable. Using the delay signals, skew may be compensated from 2 to 65 nanoseconds in 2 nanosecond increments on each individual color pair. If skew compensation is required, but the skew comp module is not installed, call for technical assistance.

An image file is available to assist in these settings. See Figure 3-8 for an example.

1. To adjust individual colors, press the EQ/Skew knob until the desired color LED is on for the R/G/B LED (AC1211A, AC1013A-R2) or the desired color LED is lit (AC1014A-R2). The LED color corresponds to the color channel being adjusted.
2. Using the image utility, turn knob to add/subtract delay timing until a single vertically aligned line of red, green, blue is obtained.
3. When complete press EQ/Skew knob until R/G/B LED (AC1211A, AC1013A-R2) is off or all LED's are off (AC1014A-R2).

Not all colors will have the same delay settings.

Cable Skew Compensation Setting Utility

Adjust skew equalizer to align Red, Green and Blue lines so they are stacked one on top of the other. Next, check white and black lines. Make fine adjustments until there is a minimum of color fringing.

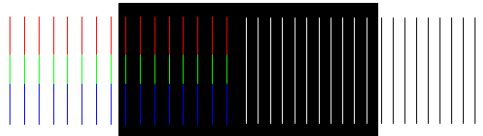

Figure 3-8: Image Adjustment Utility—Skew

CAT5 MULTI VGA SYSTEM

3.3 TYPICAL APPLICATIONS

Figures 3-9 to 3-11 show typical applications:

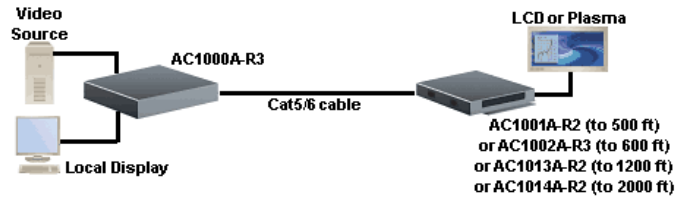

Figure 3-9. Point to Point Application

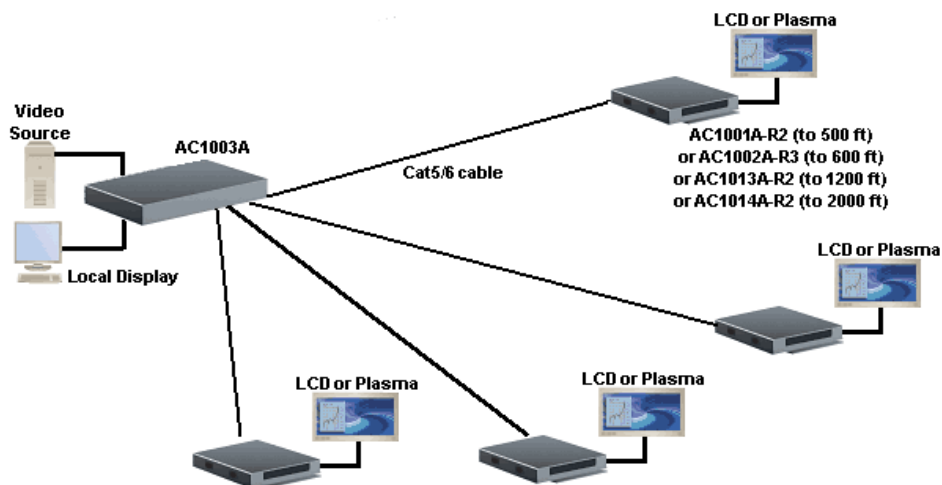

Figure 3-10. 4 Display Distribution

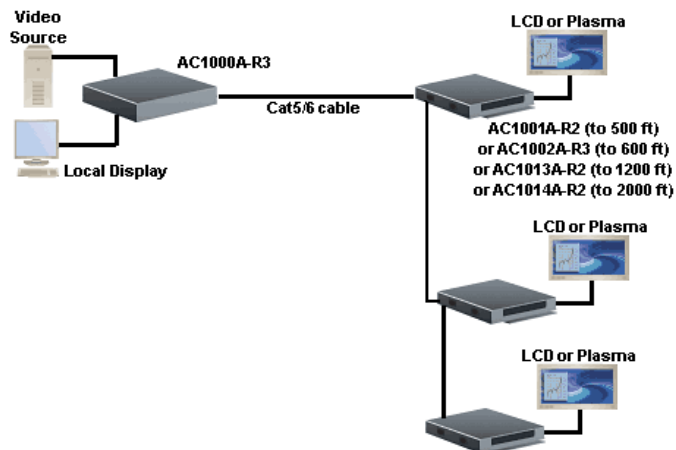

Figure 3-11. Daisy Chain Distribution

4. Troubleshooting

4.1. Common Problems

In most cases, nearly every issue with the CAT5 Multi VGA System can be resolved by checking the CAT5 termination and making sure that it's pinned to the TIA/EIA 568B wiring specification. However, there may be other problems that cause the system to not perform as it's designed. Below are solutions to the most common installation errors.

- Problem:** No video signal at the transmitter local port or at the receiver.
Solution:
- Check that both units are powered.
 - Make sure the CAT5 cable is terminated correctly per the TIA/EIA 568B wiring specification.
 - Is the display device powered on and functioning?
 - There may be a DDC error. See Appendix F.
 - In 1080P modes, fixed sync may be necessary. See Appendix G.
- Problem:** Video signal is poor.
Solution:
- Have all receiver settings been finished (see sections 3.2).
 - Check all cable connections.
 - The video signal's refresh rate may be set too high. Reset to a lower refresh rate in your monitor-configuration menu.
 - There may be a delay skew issue. Call Technical Support.
- Problem:** Audio is poor.
Solution:
- Powered speakers are required. Make sure speaker power is ON.
 - Check input source levels from the source device. Make sure the audio source is not overdriven or underdriven.

CAT5 MULTI VGA SYSTEM

Problem: “Green shift” or “green washout” on multimedia signals.
Solution: Please contact Technical Support.
The standard video/serial model is designed to function with DC coupled signals in which the black level is referenced to 0 volts. Nearly all VGA cards function this way. Some media servers, however, provide AC coupled signals and can cause a green color shift in the video. This is a result of the sync clamping on the red and blue channels of the video/serial model.
For five-component (RGB/H&V) AC coupled video, the AC1000A-R3 and single port transmitters have optional DC restoration circuitry that is easily enabled via a dipswitch setting (see **Appendix B**).
Quad hub transmitters (AC1003A) do not feature this, however the local monitor output of the AC1000A-R3 can be used to fix this.

Problem: Notes on Daisy Chaining:
Solution: When daisy chaining, the maximum cable distance is not increased beyond the rated distance of the receiver used. For example, an AC1002A-R3 can daisy chain within 600 ft of the transmitter. It is possible to daisy chain out of a short range receiver into a longer range receiver. For example, over 600 ft an AC1002A-R3 can be daisy chained into on AC1013A-R2 which allows for daisy chaining to 1200 ft.
A maximum of 12 units may be daisy chained together.
If a unit in the middle of the chain loses power or is disconnected from the chain, all units beyond this point will lose signals.
Note that the middle units must have 4th pair termination off, and the last unit must have 4th pair termination on. See Appendix E.

4.2 Calling Black Box

If you determine that your CAT5 Multi VGA System is malfunctioning, do not attempt to alter or repair it. It contains no user-serviceable parts. Contact Black Box at 724-746-5500.

Before you do, make a record of the history of the problem. We will be able to provide more efficient and accurate assistance if you have a complete description, including:

- the nature and duration of the problem.
- when the problem occurs.
- the components involved in the problem.
- any particular application that, when used, appears to create the problem or make it worse.

4.3 Shipping and Packaging

If you need to transport or ship your CAT5 Multi VGA System:

- Package it carefully. We recommend that you use the original container.
- If you are shipping the CAT5 Multi VGA System for repair, make sure you include everything that came in the original package. Before you ship, contact Black Box to get a Return Authorization (RA) number.

Appendix A. Cabling Pinouts

Table A-1. HD15 video connector.

Pin	RGBHV (VGA)	RGBS	RGsB
1	Red +	Red +	Red +
2	Green+	Green+	Green+
3	Blue+	Blue+	Blue+
4	—	—	—
5	Gnd	Gnd	Gnd
6	Red-	Red-	Red-
7	Green-	Green-	Green-
8	Blue-	Blue-	Blue-
9	—	—	—
10	Gnd	Gnd	—
11	Gnd	Gnd	—
12	—	—	—
13	H Sync	C Sync	—
14	V Sync	—	—
15	Gnd	Gnd	—

Appendix A. Cabling Pinouts

**Table A-2. AUDIO connector
(AC1002A-R3, AC1013A-R2, AC1014A-R2, AC1000A-R3))**

<u>PIN</u>	<u>Audio</u>
Pin 1	Left Channel
Pin 2	Ground
Pin 3	Right Channel
Pin 4	-

Table A-3. 1/8" (3.5 mm) Audio Connection (AC1003A)

Pin	Channel 1	Channel 2
Tip	+	
Ring		+
Sleeve	-	-

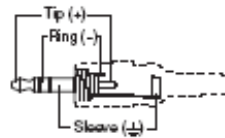

Note: The stereo audio input at the transmitter is summed and output as mono audio on both channels at the receiver.

Table A-4. T568B CAT5 pinout

T568B CAT5 Specification

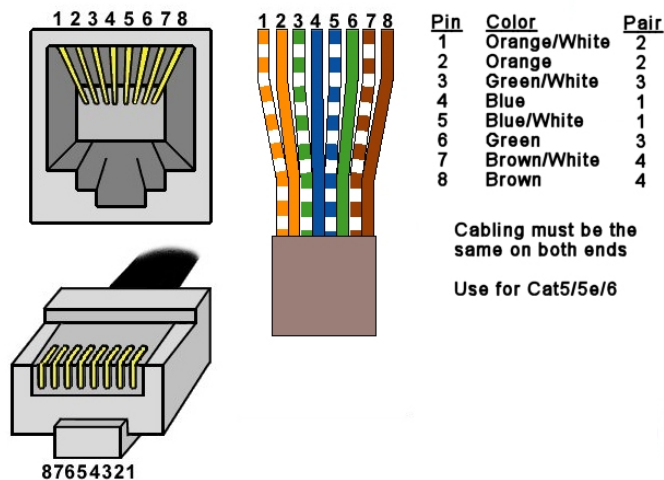

Appendix B. DC Restoration of AC coupled source

The Cat5 Multi VGA system is designed to function with DC coupled signals with the black level referenced to 0 volts. Nearly all VGA cards function this way. However, some media servers or digital camera devices provide AC coupled signals and can cause a green color shift in the video. This is a result of the sync clamping on the Red and Blue channels. The single port transmitter has been designed with full DC restore capability. A simple switch setting is all that is required.

The following diagrams show the switch location and settings for the AC1000A-R3 transmitter assembly.

Note: Switch settings other than shown below may result in unpredictable performance and are not supported by Black Box.

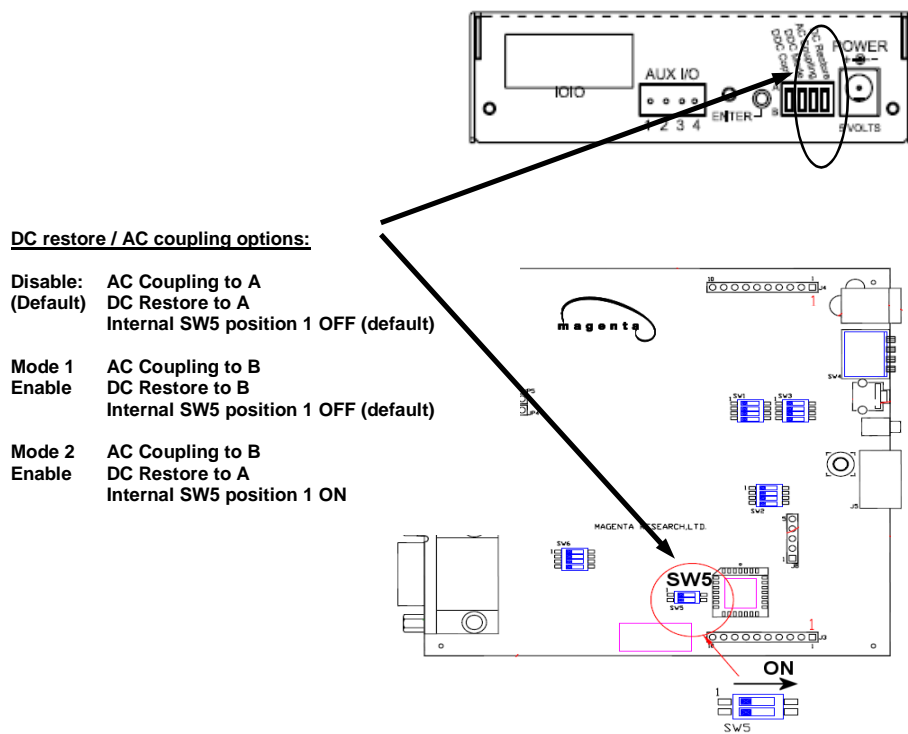

Appendix C. Receiver Video Modes

The Cat5 Multi VGA System receivers feature the ability to display five component RGBHV computer video as well as RGBS, RGsB and full component RGB video. The transmitter units need no configuration changes.

The AC1001A-R2 has an external switch (SW3) that controls whether RGBHV or non-RGBHV signals are in use. Please see silkscreen on the top cover of the unit for the SW3 position to use.

The AC1002A-R3, AC1013A-R2, AC1014A-R2 feature an auto-sense mode to determine RGBHV or not is in use. This mode can be overridden if necessary as shown below:

Figure C-1. Auto Sync Modes AC1002A-R3, AC1211A, AC1013A-R2

AUTO SYNC MODES:

JP8 controls sync clamping circuitry and works with the external switch labeled AUTO CLAMP.

The default sync mode is AUTO CLAMP OFF which will autosense between RGBHV and non-RGBHV signals.

Turning the External AUTO CLAMP switch ON will set the sync clamp mode to RGBHV video modes

If non-RGBHV video is desired with AUTO CLAMP ON, jumper JP8 must be set to IN.

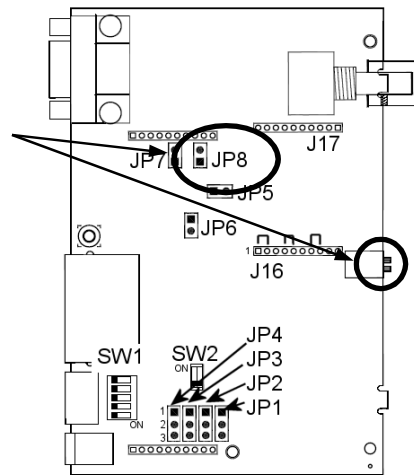

Figure C-2. Auto Sync Modes AC1014A-R2

JP13 controls sync clamping circuitry and has 3 settings depending on the video signal in use:

RGBHV computer video with separate horizontal and vertical sync:
Jumper JP13 to positions 1-2

Non RGBHV video, component RGB/YUV, S-video, composite video or RGsB video:
Jumper JP13 to positions 2-3

Auto sense video mode:
JP13 non-jumpered.

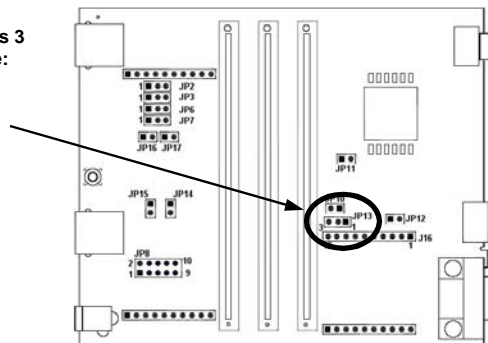

Appendix D. Rackmounting Units

The Cat5 Multi VGA System components can be rack mounted in 19" wide cabinets. Below is a table showing the various rackmount kits available . Figure D-1 shows a typical rackmount application.

Transmitters:

PN	Rackmount PN	Description
AC1000A-R3	AC1009	19" 1U high kit for 4 units horizontally.
	AC1010	19" 2U high kit for 2 rows of 4 units
AC1003A	AC1011	19" 1U high kit for 3 units horizontally.
	AC1012	19" 2U high kit for 2 rows of 3 units

Receivers:

AC1001A-R2 no rackmount options

AC1002A-R3, AC1211A, AC1013A-R2, AC1014A-R2

Use AC1011 or AC1012 described above

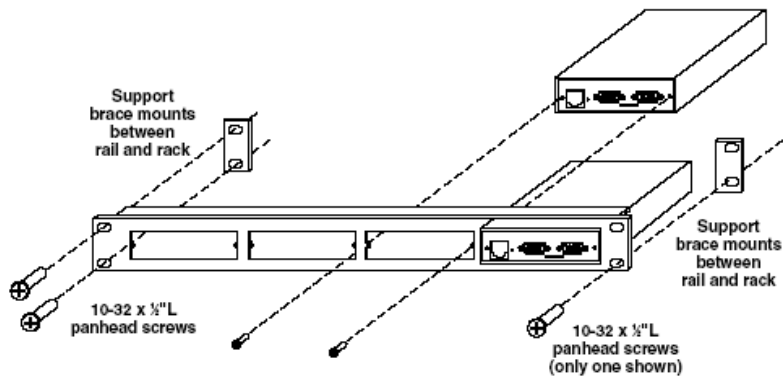

Figure D-1. Mounting with the AC1009 kit.

Appendix E. Daisy Chain Termination

The Cat5 Multi VGA System receiver units with a UTP output can be daisy chained along a single cat5. This applies to the AC1002A-R3, AC1013A-R2, and the AC1014A-R2. The AC1001A-R2 does not have this capability. When daisy chaining, it is important to ensure units have proper termination at the end, but no termination in the middle units. This has no affect on the video signals, but will affect the audio signals.

To enable/disable termination on the AC1002A-R3 and AC1013A-R2, the external TERM switch is used. To enable termination at the end of a daisy chain, set the TERM switch to ON. Set switch to OFF when units are in the middle of the daisy chain. See figure below:



To enable/disable termination on the AC1014A-R2, two jumpers internally need to be in or out. This involves removing the top cover assembly and installing or removing two jumpers. See figure below for the locations:

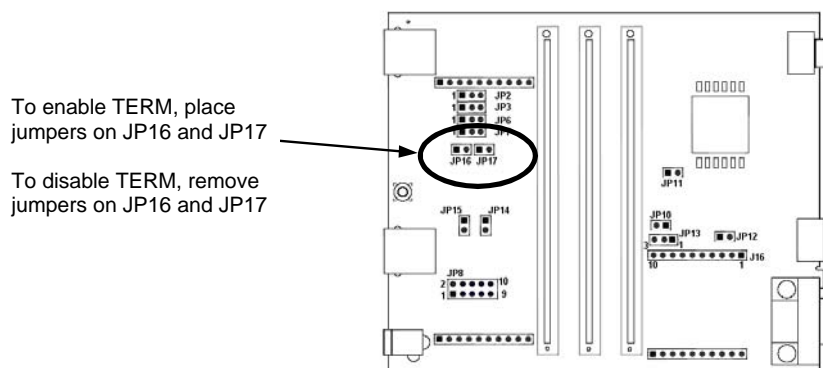

Appendix F. DDC Modes

The AC1000A-R3 features the ability to send DDC/EDID display identifiers to the video source in order to determine display capabilities. The DDC is a data communication channel used in plug and play devices to accurately report a displays capabilities and identify the manufacturer. If this data is not available, the video source may revert to a low resolution or not display at all.

The AC1000A-R3 features the ability to report a Universal Display (MRI Magic Display) that supports most popular VESA standards in standard or widescreen formats as well as the ability to clone an actual displays DDC information that is attached to either the local output of the transmitter or copied from an actual display.

The AC1000A-R3 transmitter unit has 3 DDC modes of Operation:

Mode 1: DDC Mock Mode

This is the default mode which uses generic DDC information stored within the transmitter and reports this to the video source when requested.

To activate this mode, set the DDC Mode switch to the A position.

Mode 2: DDC from Local Monitor Port

The DDC information is transferred from a display connected to the local port of the transmitter back to the video source. The local monitor must remain connected at all times.

To activate this mode, set the DDC Mode switch to the B position.

Mode 3: Copy DDC information from a display into the AC1000A-R3 memory.

In this mode, DDC information is first copied from a display into the AC1000A-R3 transmitter and stored in non-volatile RAM. Then the transmitter is connected to a video source and reports the copied DDC information to the video source when requested.

To activate this mode, set the DDC Copy switch to the B position and do the following:

- **Connect Display to the Local monitor port on the transmitter**
- **Set DDC Copy switch to B**
- **Press the Enter button**
- **DDC LED will flash 3 times indicating a successful copy.**
- **Disconnect display and reconnect video source.**

To restore the default generic DDC information:

- Set DDC Copy switch to A, then press the Enter button
- The DDC LED will flash 2 times to confirm restoration.

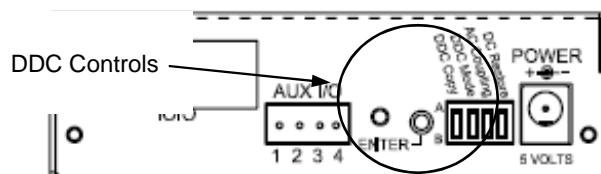

Appendix G. Setting Sync Mode

The AC1000A-R3 has the capability for fixed and agile sync. The default sync mode setting is for agile sync which replicates the source sync polarity signals. However some displays require a fixed sync polarity that is not possible to change at the video source. 1080P signals may also require this mode if the sync is a very narrow pulse.

**NOTE: Both transmitter and receiver must have the same settings.
Not all transmitter/receivers support this function.**

Jumper Setting	SW5
Fixed Sync	1 N/A 2 ON
Agile Sync (default)	1 N/A 2 Off

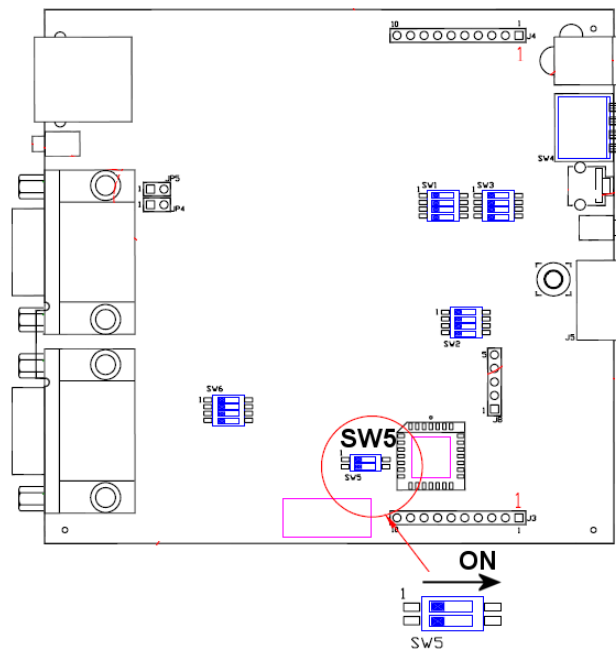

Appendix G. Setting Sync Mode

The AC1002A-R3, AC1211A, AC1013A-R2, AC1014A-R2 have the capability for fixed and agile sync. The default sync mode setting is for agile sync which replicates the source sync polarity signals. However some displays require a fixed sync polarity that is not possible to change at the video source.

1080P signals may also require this mode if the sync is a very narrow pulse.

The following details jumper settings to change the sync polarity of the horizontal and vertical sync signals (*Note that jumpers have no affect in agile mode*):

AC1002A-R3, AC1211A, AC1013A-R2

Jumper Setting	JP5	JP6	JP7
Fixed Sync	IN	-	-
Agile Sync (default)	OUT	-	-
Horizontal Sync Positive	-	IN	-
Horizontal Sync Negative	-	OUT	-
Vertical Sync Positive	-	-	IN
Vertical Sync Negative	-	-	OUT

AC1014A-R2

Jumper Setting	JP10	JP11	JP12
Fixed Sync	IN	-	-
Agile Sync (default)	OUT	-	-
Horizontal Sync Positive	-	IN	-
Horizontal Sync Negative	-	OUT	-
Vertical Sync Positive	-	-	IN
Vertical Sync Negative	-	-	OUT

AC1002A-R3, AC1211A, AC1013A-R2

Sync Mode jumpers
JP5, JP6, JP7

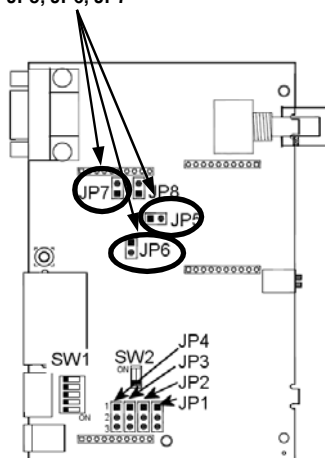

AC1014A-R2

Sync Mode jumpers
JP10, JP11, JP12

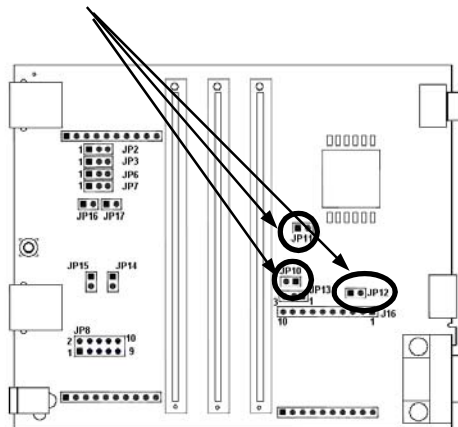



© Copyright 2008. Black Box Corporation. All rights reserved.

1000 Park Drive • Lawrence, PA 15055-1018 • 724-746-5500 • Fax 724-746-0746

5320013-01 Rev 02